

Project Value	\$2m
Man hours	5860h
Shut duration	21 days
Incidents	0
LTIs	0
MTIs	0

Liberty Onesteel ESP 2 Rebuild

March 2018

Project Brief

Precipitator Technologies (PrecipTech) completed the rebuild of ESP 2 at Liberty Onsteel one day ahead of schedule during a 21 day window in March 2018. The complex project was completed incident and injury free after almost 6000 man hours. The project was completed ahead of time and ahead of budget (\$2 million).

New GDS Rapper System

A new gas distribution screen rapper was installed to prevent blockages and improve collection efficiency.

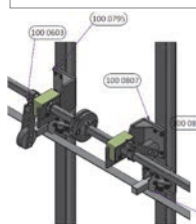

New ICVHS

A new blower-heater system was installed to help prevent insulator breakage which will improve reliability and reduce maintenance costs.



New Equipment

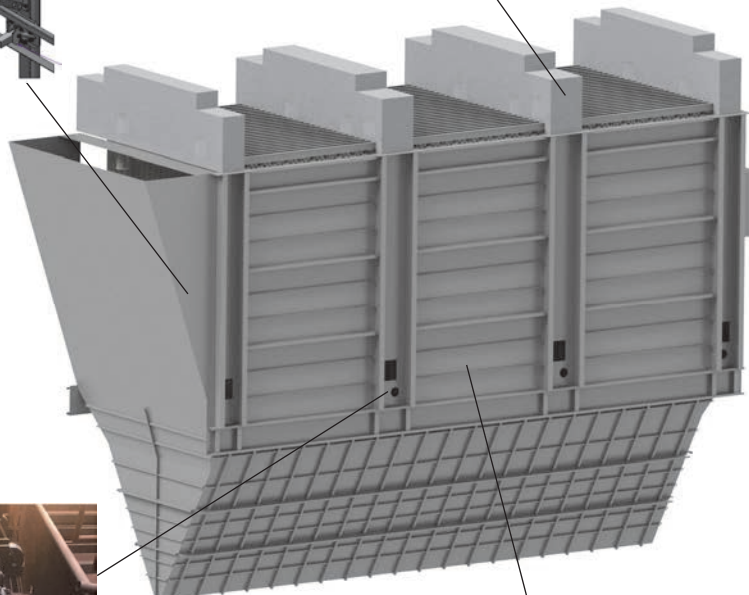

Upgraded Rapping Systems

Three new rapper shafts each with 21 hammers were installed with a new huck-bolted design to improve reliability and reduce maintenance costs.

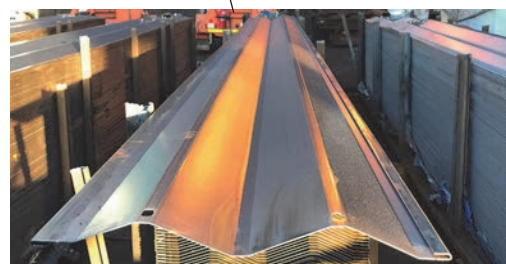

New Collecting plates

A complete set of 546 new collecting plates were installed to replace the old damaged plates.

General Maintenance

In addition to the upgrade work a large amount of general maintenance work was completed. This included detailed thickness testing of the casing and numerous repairs. Also, there were repairs made to the discharge electrode frames and rapping system as well as many other tasks.

ph +61 2 4276 2275

www.PrecipTech.com.au

Liberty Onesteel ESP 2 Rebuild

March 2018

Electrical Upgrades - Improved power supply and control

Using a combination of B&W "Juice Cans" and advanced SQ300i Hybrid controllers has allowed the power levels within the ESP to be increased dramatically. During commissioning the precipitator fields were achieving over 200 kVA power levels which represents a four fold increase in power from before the rebuild.



Upgrade to B&W SQ300i Hybrid Controllers
New Advanced control circuits have been installed on each field

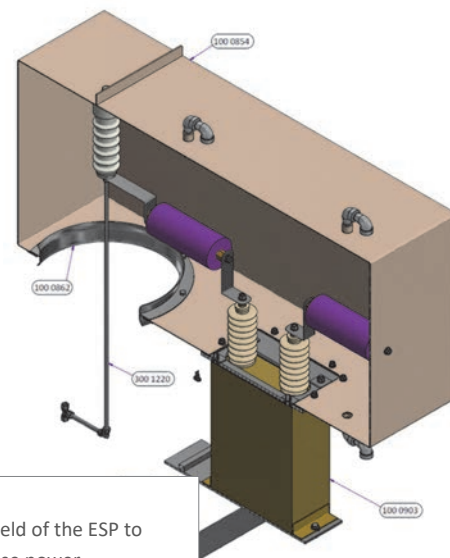

New B&W Juice Cans
A Juice Can was installed on each field of the ESP to reduce secondary ripple and increase power.

New ICVHS
A new blower-heater system was installed to help prevent insulator breakage which will improve reliability and reduce maintenance costs.

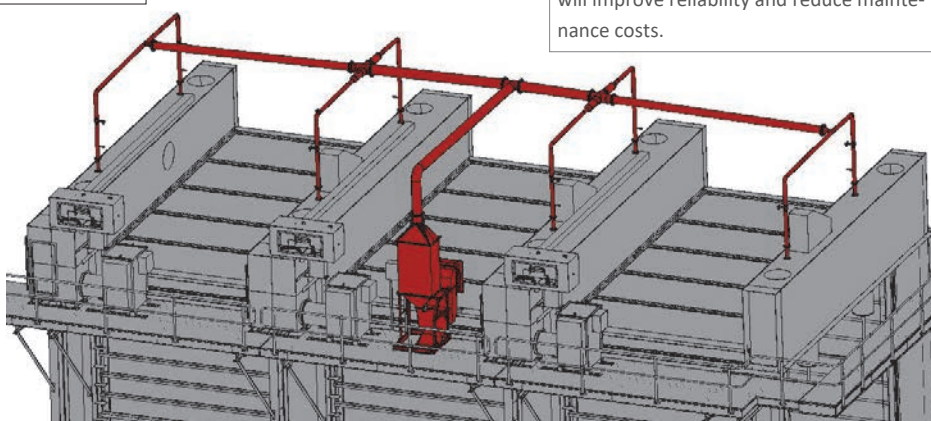

Project Outcomes

Prior to the rebuild the precipitator was in a very poor state of repair and was only generating around 43.4 kVA of power. After the rebuild the power levels have increased dramatically to over 200 kVA (365% increase). This has had a very large impact on collection efficiency and has directly reduced the emission from the BOS plant. Additionally, all of the new systems installed have greatly improved the reliability of the precipitator which has increased the availability of the unit and reduced maintenance costs.

"Thanks to everyone at Preciptech for a professional and high-quality project. The fact that we completed the job without any safety incidents and a day ahead of the program is a great credit to all of you."

ph +61 2 4276 2275
www.PrecipTech.com.au

- Liberty Onesteel Project Manager



The Electrostatic Precipitator Specialists

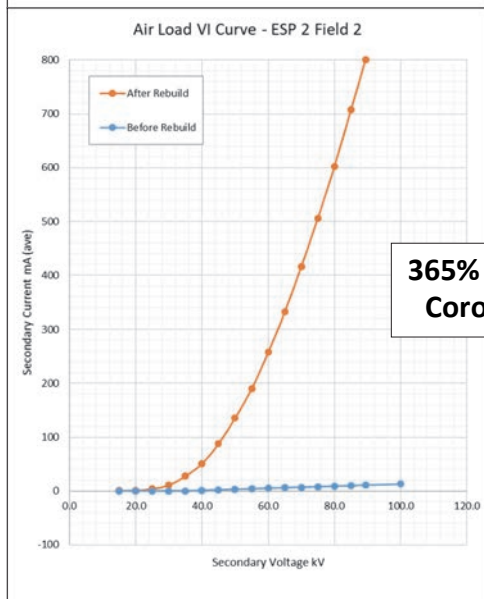
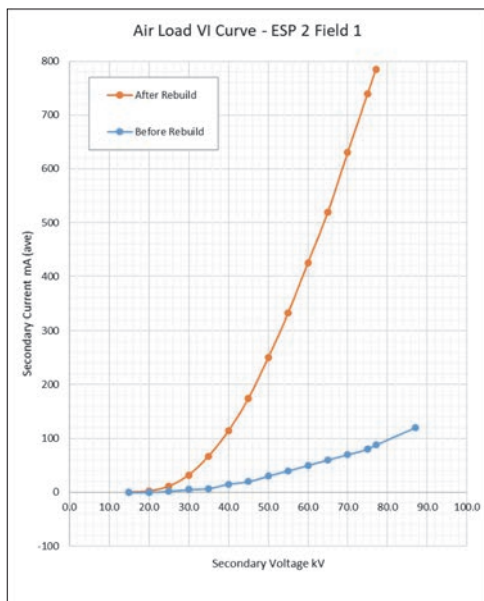

365% Increase in Corona Power

